

MEBLE WARSZTATOWE

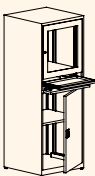

						
Oznaczenie	SmK	SmKa	SmK1	SmK1a	SmK 4a	SmK 4a
Kod	SMK 0101010201	SMK 0101010202	SMK 0101010101	SMK 0101010102	SMK 0101010105	SMK 0101010205
Wysoko (mm)	1750					
Szeroko (mm)	640					
Gł boko (mm)	630					
Wyposa enie	Cze chroni ca klawiatur otwierana jednocze nie z drzwiami głównymi. Szafka z wyposa eniem - wentylatorem i listw zasilaj c .	Cz chroni c klawiatur otwierana oddzielnie. Szafka z wyposa eniem - wentylatorem i listw zasilaj c .	Cz chroni ca klawiatur otwierana jednocze nie z drzwiami głównymi. Szafka bez wyposa enia - bez wentylatora i listwy zasilaj cej.	Cze chroni ca klawiatur otwierana oddzielnie. Szafka bez wyposa enia - bez wentylatora i listwy zasilaj cej.	Szafa wyposa ona w: - cz chroni c klawiatur - regulowan półk	Szafa wyposa ona w: - cz chroni c klawiatur - regulowan półk - wentylator

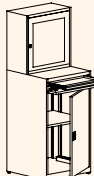

Biuro handlowe
ul. Warszawska 138, 21 - 080 Garbów
tel. 81 501 50 37, www.korina.com.pl

biuro@korina.com.pl; beatak@korina.com.pl
handlowiec@korina.com.pl; andrzejf@korina.com.pl

MEBLE WARSZTATOWE



SPNK

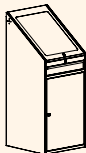
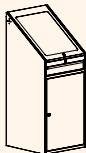
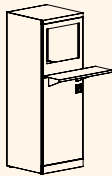
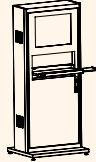

SmK 2

				
Oznaczenie	SmK 3A	SmK 3A	SmK 2	SPNK
Kod	SMK 0405010104	SMK 0405010204	SMK 0202030203	SMK0506050506
Wysoko (mm)	1545		1600	1770
Szeroko (mm)	640		550	755
Gł boko (mm)	635		550	330
Wyposa enie	<p>Szafka bez osprz tu elektrycznego wyposa ona w:</p> <ul style="list-style-type: none"> - szuflad na klawiatur , - wysuwan półk w dolnej komorze, - na bocznych cianach wentylacja, - w tylnych cianach znajduj si otwory na przewody zasilaj ce. 	<p>Szafka z osprz tem elektrycznym (wentylatorem i listw z gniazdami) wyposa ona w:</p> <ul style="list-style-type: none"> - szuflad na klawiatur , - wysuwan półk w dolnej komorze, - na bocznych cianach wentylacja, - w tylnych cianach znajduj si otwory na przewody zasilaj ce. 	<p>Szafa wyposa ona w:</p> <ul style="list-style-type: none"> - półk (na klawiatur i myszk) mocowan na stałe (monta u klienta), - wentylator, - listw na cztery gniazda. 	<p>Szafa wyposa ona w:</p> <ul style="list-style-type: none"> - wentylator, - kabel zasilaj cy, - przył cze, - listw zasilaj c z filtrem przeciwzakłóceniowym.



Biuro handlowe
 ul. Warszawska 138, 21 - 080 Garbów
 tel. 81 501 50 37, www.korina.com.pl

biuro@korina.com.pl; beatak@korina.com.pl
handlowiec@korina.com.pl; andrzejf@korina.com.pl

MEBLE WARSZTATOWE



Oznaczenie	Sbm 203W	Sbm 212W	Swm 205	Szwn 251	Szwn 252
Kod	SBM 03030304	SBM 04030304	SWM 0202030402	GWJ 0101020702	GWJ 0101010802
Wysoko (mm)	1990			928	
Szeroko (mm)	1000	1200	1000	961	
Gł boko (mm)	435			600	
Wyposażenie	Ilo pótek: 4		Ilo pojemników: małe: 80 szt. na ka dych drzwiach du e: 72 szt. na cianie tylnej Wymiary pojemników: małe: 56 x 77 x 119/90 du e: 108 x 144 x 224/170	5 szuflad, w tym 1 gł boka	



Biuro handlowe
 ul. Warszawska 138, 21 - 080 Garbów
 tel. 81 501 50 37, www.korina.com.pl

biuro@korina.com.pl; beatak@korina.com.pl
handlowiec@korina.com.pl; andrzejf@korina.com.pl

MEBLE WARSZTATOWE

VALBERG



Master 101 (z półk)



Master 102 (z blatem bez nakładki)



Master 103 (z szu?ad)



Master 104



Master 105
(z dwiema szu?adami i półk)



Master 106
(z dwiema półkami)



(z szu?ad i półk) Master 109
(z dwiema półkami i szu?ad)



Master 110
(z trzema szu?adami)



Master 111
(z dwiema szu?adami)



Master 107
(dwa stoły warsztatowe ze wspóln podpor)



Mo liwo przechowywania opon samochodowych R15 195/65, R16 205/55



Biuo handlowe
ul. Warszawska 138, 21 - 080 Garbów
tel. 81 501 50 37, www.korina.com.pl

biuro@korina.com.pl; beatak@korina.com.pl
handlowiec@korina.com.pl; andrzejf@korina.com.pl

MEBLE WARSZTATOWE

VALBERG

■ Stoly 1000 mm



WT 100.F1/F1.000



WT 100.WD1/F1.000



WT 100.WD2/F1



WT 100.WD5/F1.000



WT 100.WD5/WD1.000

■ Stoly 1200 mm



WT 120.F1/F1.000



WT 120.WD1/F1.000



WT 120.WD2/F1.000



WT 120.WD5/F1.000



WT 120.WD5/WD1.000

■ Stoly 1400 mm



WT 140.WD1/F1.000



WT 140.WD2/F1.000



WT 140.WD5/F1.000



WT 140.WD5/WD1.000



WT 140.WD2/WD1.000

■ Stoly 1600 mm



WT 160.WD1/F1.000



WT 160.WD2/F1.000



WT 160.WD5/F1.000



WT 160.WD1/WD2.000



WT 160.WD5/WD5.000

■ Stoly 1800 mm



WT 180.WD1/WD1.000



WT 180.WD1/WD2.000



WT 180.WD2/WD5.000



WT 180.WD1/WD5.000



WT 180.WD5/WD5.000



Biuro handlowe
ul. Warszawska 138, 21 - 080 Garbów
tel. 81 501 50 37, www.korina.com.pl

biuro@korina.com.pl; beatak@korina.com.pl
handlowiec@korina.com.pl; andrzejf@korina.com.pl

MEBLE WARSZTATOWE

VALBERG

Stoly 1200 mm



W120.F2/F2.000



W120.F2/WS1.000



W120.WS6/F2.000



W120.WS1/WS6.000

Stoly 1600 mm



WTS160.F2/F2.000



W160.F2/WS1.000



WTS 160.F2/WS6.000



W 160.WS6/WS1.000

Stoly 2000 mm



W200.F2/F2.000



WTH200.WS1/F2.000



W200.F2/WS6.100



WTS200.WS6/WS1.000



WTH200.WS6/WS6.000



Biuro handlowe
ul. Warszawska 138, 21 - 080 Garbów
tel. 81 501 50 37, www.korina.com.pl

biuro@korina.com.pl; beatak@korina.com.pl
handlowiec@korina.com.pl; andrzejf@korina.com.pl

MEBLE WARSZTATOWE

VALBERG



TC 1095-001010



TC 1095-021000



TC 1095-021010



TC 1095-021020



TC 1095-002020



TC 1095-001030



TC 1095-002000



TC 1095-002020



TC 1095-100302



TC 1095-100206



TC 1095-100215



TC 1095-1002010



Biuro handlowe
ul. Warszawska 138, 21 - 080 Garbów
tel. 81 501 50 37, www.korina.com.pl

biuro@korina.com.pl; beatak@korina.com.pl
handlowiec@korina.com.pl; andrzejf@korina.com.pl



TC 1995-042000



TC 1995-042020



TC 1995-041030



TC 1995-041040



TC 1995-004000



TC 1995-004020



TC 1995-003040



TC 1995-100600



TC 1995-120402



TC 1995-10060.10



TC 1995-121015



TC 1995-12100.10

MEBLE WARSZTATOWE

VALBERG



AMH TC-004000



AMH TC-004010



AMH TC-062000



AMH TC-005020



AMH TC-003040



AMH TC-062030



AMH TC-062032



z półkami SK-40

AMH TC-003000



z półkami SK-50

AMH TC-004000



Biuro handlowe
ul. Warszawska 138, 21 - 080 Garbów
tel. 81 501 50 37, www.korina.com.pl

biuro@korina.com.pl; beatak@korina.com.pl
handlowiec@korina.com.pl; andrzejf@korina.com.pl

MEBLE WARSZTATOWE

VALBERG



Hard 2000 - 000000



Hard 2000 - 004001



Hard 2000 - 004011



Hard 2000 - 004012



Hard 2000 - 033001



Hard 2000 - 033011



Hard 2000 - 033012



Hard 2000 - 033013



Hard 2000 - 009011



Hard 2000 - 062012



Hard 2000 - 062000



Hard 2000 - 062011



Biuro handlowe
ul. Warszawska 138, 21 - 080 Garbów
tel. 81 501 50 37, www.korina.com.pl

biuro@korina.com.pl; beatak@korina.com.pl
handlowiec@korina.com.pl; andrzejf@korina.com.pl